



Koldware 4AK 10 and 14 AirMaster Installation & Operation Manual

ATTENTION: READ THIS MANUAL, FACTORY INSTALLED OPTIONS MANUAL, UNIT SUBMITTAL DATA SHEETS AND ALL LABELS ATTACHED TO THE UNIT CAREFULLY BEFORE ATTEMPTING TO INSTALL, OPERATE OR SERVICE THESE UNITS. CHECK DATA PLATES FOR ELECTRICAL SPECIFICATIONS AND MAKE CERTAIN THAT THESE AGREE WITH THOSE AT THE POINT OF INSTALLATION. RECORD THE UNIT MODEL AND SERIAL NUMBER IN THE SPACE PROVIDED. RETAIN THIS DOCUMENT FOR FUTURE REFERENCE.

Model No. _____ Serial No. _____

IMPROPER INSTALLATION, ADJUSTMENT, ALTERATION, SERVICE OR MAINTENANCE CAN CAUSE PROPERTY DAMAGE, INJURY OR DEATH. THIS APPLIANCE MUST BE INSTALLED BY A LISCENCED CONTRACTOR OR QUALIFIED SERVICE PERSONNEL. READ THESE INSTALLATION, OPERATING AND MAINTENANCE INSTRUCTIONS THOROUGHLY BEFORE INSTALLING OR SERVICING THE UNIT.

WARNING: INSTALL, OPERATE AND MAINTAIN UNIT IN ACCORDANCE WITH MANUFACTURER'S INSTRUCTIONS TO AVOID ANY DETURING FACTORS THAT MAY CAUSE PERSONAL INJURY OR PROPERTY DAMAGEDAMAGE.

INSTALLER'S RESPONSIBILITY: THIS EQUIPMENT HAS BEEN RUN TESTED AND INSPECTED THOROUGHLY. IT HAS BEEN SHIPPED FREE FROM DEFECTS FROM OUR FACTORY. HOWEVER, DURING SHIPMENT AND INSTALLATION, PROBLEMS SUCH AS LOOSE WIRES, LEAKS OF LOOSE FASTENERS MAY OCCUR. IT IS THE INSTALLER'S RESPONSIBILITY TO INSPECT AND CORRECT ANY PROBLEMS THAT MAY BE FOUND.

RECEIVING INSTRUCTIONS: INSPECT SHIPMENT IMMEDIATELY UPON ARRIVAL TO DETERMINE IF ANY DAMAGE HAS OCCURRED TO THE UNIT DURING SHIPMENT. AFTER THE UNIT HAS BEEN UNCRATED, CHECK FOR ANY VISIBLE DAMAGE TO THE UNIT. IF ANY DAMAGE IS FOUND, THE CONSIGNEE SHOULD SIGN THE BILL OF LADING INDICATING SUCH DAMAGE AND IMMEDIATELY FILE A CLAIM FOR DAMAGE WITH THE TRANSPORTATION COMPANY.

General Information

The Koldwave Airmaster is a portable, air-cooled air conditioner/zone cooler suitable for indoor/outdoor use. The Koldwave Airmaster can cool an entire area by discharging air through its 16" x 4" grille. This self-contained unit is also designed to direct cool air to specific areas or objects through (optional) dual 4" diameter nozzles.

This provides precision cooling for heat-sensitive equipment, production processes and personnel.

The cord-connected Koldwave Airmaster is provided with heavy-duty casters. The swivel-locking front casters prevent sliding and stationary rear casters provide handling ease for conventional relocation. This unit is completely self-contained with the entire refrigeration system, electrical components, condenser and evaporator housed in one attractively designed, stainless steel metal cabinet.



IMPORTANT: The Koldwave AirMaster unit has been designed and engineered to provide needed cooling within the performance parameters of this manual. Following the installation and preventative maintenance instructions can extend the length of service you receive.

Capacity Tables

Evaporator Fan Speed Conditions	010					
	High			Low		
	Total	Sensible	EER*	Total	Sensible	EER*
67°F DB/57°F WB (54% RH)	9,148	6,653	9.71	8,261	5,568	9.31
72°F DB/60°F WB (50% RH)	9,627	7,113	9.83	8,586	5,906	9.32
75°F DB/62°F WB (48% RH)	9,903	7,287	9.86	8,867	6,103	9.38
80°F DB/67°F WB (52% RH)	10,613	7,223	10.13	9,749	6,051	9.82
95°F DB/75°F WB (40% RH)	11,970	8,783	10.00	11,161	7,314	9.81
95°F DB/83°F WB (61% RH)	12,985	6,021	10.79	11,973	5,186	10.42
104°F DB/80°F WB (36% RH)**	12,603	9,399	9.67	11,600	7,917	9.35

Evaporator Fan Speed Conditions	014					
	High			Low		
	Total	Sensible	EER*	Total	Sensible	EER*
67°F DB/57°F WB (54% RH)	10,714	7,736	9.44	9,409	6,216	8.86
72°F DB/60°F WB (50% RH)	11,200	8,328	9.47	9,933	6,586	8.92
75°F DB/62°F WB (48% RH)	11,534	8,538	9.49	10,238	6,795	8.93
80°F DB/67°F WB (52% RH)	12,606	8,375	9.92	11,262	6,757	9.32
95°F DB/75°F WB (40% RH)	14,054	10,248	9.63	12,783	8,069	9.20
95°F DB/83°F WB (61% RH)	14,917	6,986	10.07	14,054	5,902	9.88
104°F DB/80°F WB (36% RH)**	14,686	11,203	9.21	13,626	8,725	8.95

Time delay fuses and circuit breakers are recommended.

* EER determined with condenser discharge air ducted into another area on high fan speed.

** Maximum operating condition.

*** Electrical ratings per U.L Standard 484 at 95°F DB/75° WB on high speed.

Specification and Electric Data

	<u>010</u>		<u>014</u>	
ELECTRIC DATA ***				
Voltage/Phase/Hertz	115/1/60		115/1/60	
Amperage	13.2		15.5	
Fuse Size (Amps)	15		20	
Watts	1196		1563	
Inrush Current (Amps)	69.7		79.70	
COMPRESSOR				
Horsepower	.75		1	
Watts	845		1080	
RLA	7.4		9.7	
LRA	44		54	
RPM	3400		3400	
Refrigerant - 22 (oz.)	25		32	
BLOWER (EVAPORATOR)				
Speed	High	Low	High	Low
Amps	1.4	0.8	1.4	0.8
Watts	139	87	134	89
CFM @ 0.0" H2O E.S.P. with Grille	440	300	400	265
BLOWER (CONDENSER)				
Speed	High	Low	High	Low
Amps	4.2	3.0	4.2	3.0
Watts	250	164	250	164
CFM @ 0.0 E.S.P.	730	515	730	515
CFM @ 0.25 E.S.P.	610	450	610	450
CONDENSATE PUMP				
Power Consumption with pump on	30		30	
Lift (Ft. of H2O)	19.5		19.5	
EVAPORATOR				
Number of Rows	2		3	
Coil Face Area (Ft.2)	1.5		1.5	
CONDENSER				
Number of Rows	3		3	
Coil Face Area (Ft.2)	2.44		2.44	
EVAPORATOR AIR FILTER SIZE (INCHES)				
Width	15.125		15.875	
Height	18		18	
Thickness	0.5		0.5	
CONDENSER AIR FILTER SIZE (INCHES) 2/UNIT				
Width	19.25		19.25	
Height	16.5		16.5	
Thickness	0.5		0.5	
UNIT DIMENSIONS (INCHES)				
Height with Casters	34.25		34.25	
Height without Casters	31.125		31.125	
Width	25.00		25.00	
Depth	24.00		24.00	
NET UNIT WEIGHT (LBS.)	182		185	
SHIPPING WEIGHT (LBS.)	207		210	

KOLDWAVE 4AK (AIRMMASTER)

STANDARD FEATURES/UNIT CONSTRUCTION

FEATURES

- Optional 10' flexible duct extends up to 10 feet to vent condenser air.
- Four way adjustable grilles control air discharge for even, comfortable cooling.
- Convenient control panel houses on-off switch, thermostat and indicator lights.
- Hinged panel allows easy access to 5-gallon condensate holding tank.
- Large, heavy-duty casters allow you to move the Koldwave® Airmaster to virtually any location.

SERVICEABILITY

The Koldwave Airmaster has removable panels to provide full service accessibility. The interior is divided into three sections. The upper front face encloses the evaporator coil and blower assembly. The lower front section contains the electrical controls, which are secured to the removable front panel, and the condensate holding tank and its level detection system. The rear section encases the compressor, condenser coil and blower assembly.

Back



Right Side



Front

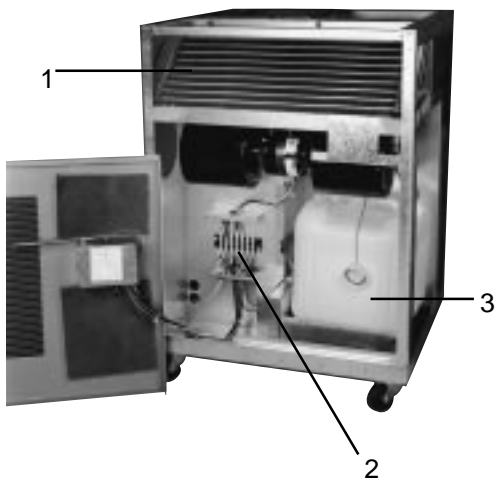

Left Side

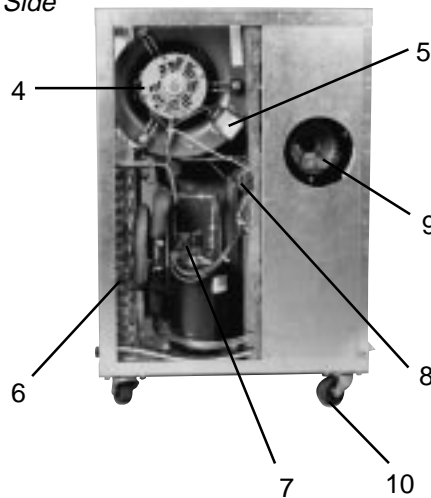

1. Evaporator Coil
2. Terminal Block Enclosure
3. Condensate Holding Tank
4. Condenser Fan Motor
5. Fan Motor Capacitor
6. Condenser Coil
7. Compressor (Rotary)
8. Compressor Capacitor
9. Evaporator Blower
10. Casters

Cabinet

The Koldwave Airmaster cabinet is constructed of stainless steel finish for ultimate corrosion protection. It is lined with thermal and sound absorbent insulation material in the discharge area and vibration dampening on all panels. Top and bottom hinged access doors are secured by magnetic strips.

Touch Pad Controls & Remote

All models have self-contained thermostats to provide the desired amount of cooling, which can be selected by adjusting the Up and Down arrows on the unit touch pad or remote controls. (Please refer to the Unit Operation for detailed explanation)

Discharge Air Grill

The Koldwave Airmaster is equipped with one 16 x 12.5 plastic grille, located in the upper front panel, to provide a cool and quite air flow.

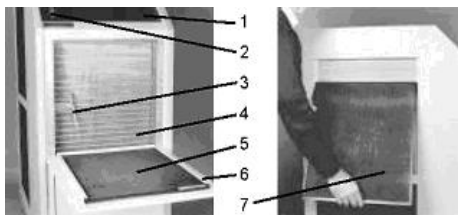

1. Discharge Grille
2. Control Panel
3. Thermostat Sensing Bulb
4. Evaporator Coil
5. Evaporator Filter
6. Hinged Evaporator Intake Door
7. Condenser Filter

Air Filter

The Koldwave Airmaster employs three, 1/2" thick, washable, aluminum mesh (Black) air filters, located behind the slotted

front (evaporator) air intake door and beneath the left side (condenser) panel. The evaporator filter can easily be removed and cleaned; just pull the front slotted panel down and remove the filter. The condenser filters are removed by lifting the filters up and pulling toward you and down.

Service Cord

All Airmaster units are equipped with LCDI device service cords, which reflects to the new UL484 standards. The service cords employed have plug configurations and receptacle requirements as shown in the chart below. We strongly recommend user to follow the plug configurations without manually altering the pin layout on the plug.

	20A - 250V Nema 6-20P	Nema 6 - 20R
--	--------------------------	--------------

Condensate Removal

The Koldwave Airmaster incorporates a 5.0 gallon capacity, polyethylene, condensate drain tank, located in the lower front section of the unit. A high water level cut-out switch, installed on the bulkhead behind the compressor as shown in the photo, is used to stop the entire unit's operation automatically when the tank is full of water. An adjustment screw is provided to set the desired water tank level when the unit cuts out. Turn screw clockwise to lower water level and thus decrease the tank's weight for emptying. To prevent spillage when carrying filled tank, a cap is chained to the tank top.

CAUTION: Turn unit off before emptying tank when tank full indicator display on the controller.

There are three methods in which to remove condensate water from

unit:

1. With condensate tank and water level detection system, which comes **standard** on unit. See detailed drawing and discussion below.
2. With **optional** condensate pump kit shown on page 19.
3. By gravity draining out bottom of unit. This is accomplished by connecting a hose to bottom of evaporator drain pan and routing through a 3/4" hole in base pan located just to the left of the condensate tank tray. A snap-in plug has to be removed from hole to permit this.

Water Detection System

An adjusting screw sets the desired water level in the tank anywhere from 1 gallon minimum to 4 gallon maximum. Once the desired water level in the tank has been reached the unit will shut down and not restart until the condensate tank is emptied

and replaced.

To reduce water level in tank from factory setting, turn and adjust screw clockwise...approximately:

- 2-1/2 Turns = 3.5 gallons
- 4-3/4 Turns = 2.5 gallons
- 6-3/4 Turns = 1.5 gallons

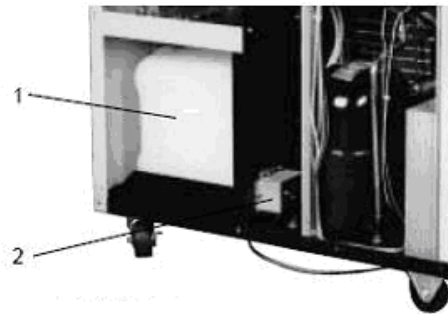

1. Condensate Tank
2. Water Level Detection Control

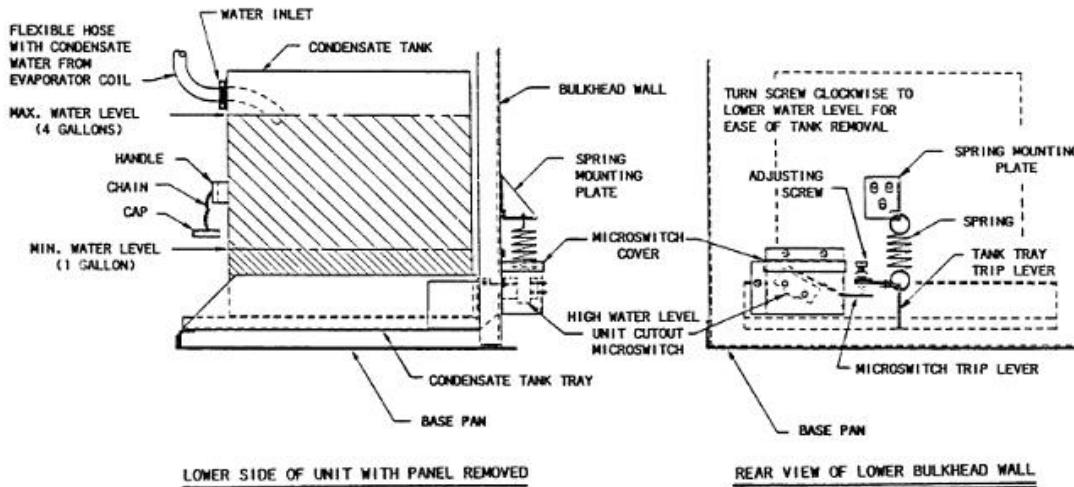

System Components

Compressor

The scroll compressor employed in the Koldwave Airmaster is the most efficient and durable on the market. Its simple design makes a major contribution to its outstanding efficiency, reliability, and quiet performance.

Coils

The condenser and evaporator have enhanced coil surfaces employing rifled tubes and louvered fins for maximum performance.

Blower Motors

The Koldwave Airmaster is equipped with a two-speed PSC condenser motor and a two-speed PSC evaporator motor for design efficient flexibility over a wide range of airflows. Both motors are of a high quality totally enclosed design with sleeve bearings.

Blowers

The Koldwave Airmaster uses two blowers instead of one to enable flexibility in duct design; lowest possible sound level and serviceability ease on both the condenser and evaporator.

Expansion Valves

Capillary tubes, maintaining precise control of the expansion process, control the refrigeration system.

General Flow Pattern

Condenser intake air is drawn in through the upper and lower sections of the unit's left-hand side panel and passes through the condenser coil, extracting heat from the refrigeration system. The hot air is discharged out the exhaust air opening located on top of the unit. Evaporator air is taken in through the middle, front slotted

evaporator intake door and is cooled by the evaporator coil. The cool air is then discharged out of the unit through a plastic grille. Both condenser and evaporator inlets are provided with filters.



Safety Controls

Compressor Overload

The scroll compressor is equipped with a current/ thermal internal overload.

High / Low Pressure Cutout

The Koldwave Airmaster incorporates, within the refrigeration system, a high-pressure switch for maximum safety of the compressor. The cutout pressure setting is 375 PSIG +/- 5 PSIG, and it will reset at 265 PSIG. A low-pressure switch is also included which opens at 26 PSIG and reset at 68 PSIG.

Duct Design

Condenser Duct

Should a longer, 12" diameter duct be needed on the condenser discharge, 10 foot flexible ducts may be coupled together up to a maximum equivalent length of 100 feet. (Allow 6 feet for every 90° bend.)

The external static pressure (E.S.P.) at the condenser discharge cannot exceed 0.25" of water. When employing more than 50 feet of duct, the noise baffle, located at the condenser discharge, should be removed (see page 25 for removal procedure.) This will prevent the unit from tripping on its high-pressure switch at high ambient.

Extended Evaporator Snozzles[®]

Should 6" diameter snozzle[®] extensions be needed on the evaporator discharge, 9.75 foot long wire-reinforced flexible duct lengths may be coupled together up to a maximum of 60 equivalent feet. (Allow 3 feet for every 90° bend.) The external static pressure (E.S.P.) at the evaporator discharge cannot exceed 0.5" of water. Exceeding this will restrict airflow and trip unit out on its low pressure switch.

Single 10" Diameter Evaporator Discharge Duct

On application where one large cold air supply duct is desired, a mounting plate with a single 10" diameter mounting flange is available, which mounts just as the snozzle[®] plate. A 10-foot length of 10" diameter wire-reinforced flexible duct can be clamped to it. Should a longer duct be desired, 10-foot duct lengths can be coupled together up to a maximum of 100 equivalent feet. (Allow 6 feet for every 90° bend.) The external static pressure at the evaporator discharge cannot exceed 0.5" of water.

Duct Clamps

Plastic wire ties suitable for 6", 10" and 12" diameter are used to secure the various flexible ducts to the unit ceiling panel, evaporator discharge panel, snozzles, and to duct couplers.

Condensate Pump Kit (Optional)

A condensate pump, capable of pumping up to 14 liters/hour, can be installed for positive removal of evaporator condensate. This kit is a convenience for those who do not wish to empty the five-gallon condensate tank periodically, especially for units with permanent installation. It is a completely automatic operation and the pump will operate only when water is present and will stop when the water has been pumped away.



KOLDWAVE 4AK (AIRMASTER)

CEILING PANEL/DUCT KIT ASSEMBLY (OPTIONAL)

A 10" diameter, flexible duct kit assembly extends up to 10 feet, to vent condenser air or to draw condenser return air from the ceiling when condenser return air plenum is used. It comes with 2' x 2' lay-in ceiling panel/collar assembly, for venting into the plenum area above the false ceiling, plus a duct collar to attach duct to unit. Installation of the flexible duct can be achieved in the following manner:

1. Slip one end of the duct over the lay-in ceiling panel/collar assembly and other end over the unit duct collar.
2. Clamp duct to lay-in ceiling panel/collar assembly and unit duct collar (see "Duct Design" for details).
3. Place the 2' x 2' lay-in ceiling panel in the false ceiling directly above the unit.
4. Screw duct collar to unit with four screws provided.



KOLDWAVE 4AK (AIRMASTER)

DUCT DESIGN

Condenser Duct

Should a longer 10" diameter duct be needed on the condenser discharge, 10 foot flexible ducts may be coupled together up to a maximum equivalent length of 60 feet (allow 6 feet for every 90° bend).

DISCHARGE AIR SNOZZLE® KIT ASSEMBLY (OPTIONAL)

A 20 gauge painted steel air discharge snozzle® mounting plate assembly can be furnished as an optional item. Its purpose is to accommodate various spot cooling applications, where air can be aimed and concentrated on the object to be cooled. The plate is designed with two 4" diameter, 16" compressed and 22" long extended flexible air duct snozzles®. The use of the snozzles® will derate the capacity by approximately 13%. The snozzle® plate is mounted over the evaporator air discharge opening by 1/4 turn Pawl Latch fasteners for each removal. It is secured in place by tightening the four fasteners provided with the plate assembly. It can be removed easily by turning the fastener on quarter turn counter-clockwise.

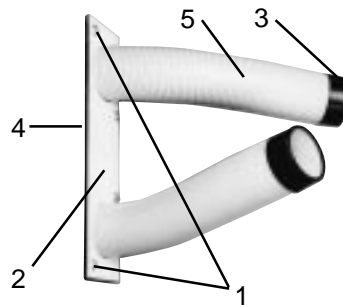

1. 1/4 Turn Pawl Latch Fasteners
2. Mounting Plate
3. Snozzle Caps
4. Insulation
5. Snozzle Duct



KOLDWAVE 4AK (AIRMASTER)

CONDENSATE RETURN AIR PLENUM (OPTIONAL)

A 20 gauge, painted steel, condenser return air plenum can be furnished for applications of the Koldwave Airmaster as a room air conditioner. This plenum is designed for use with a flexible duct kit assembly. The duct collar of the duct kit assembly can be secured with four screws over a 10" diameter hole in the top of the plenum. The duct can then be connected to the lay-in ceiling panel, so condenser return air is drawn from the false ceiling above the unit.

The plenum is mounted to the condenser air intake by sheet metal screws. A filter frame is incorporated in its design to allow easy removal of the filter for cleaning from the right side of the unit. The filter frame is made to accept the unit's standard condenser air filter with the filter handle relocated from the bottom to side of filter at installation.

NOTE: See "Application" section for typical installation.

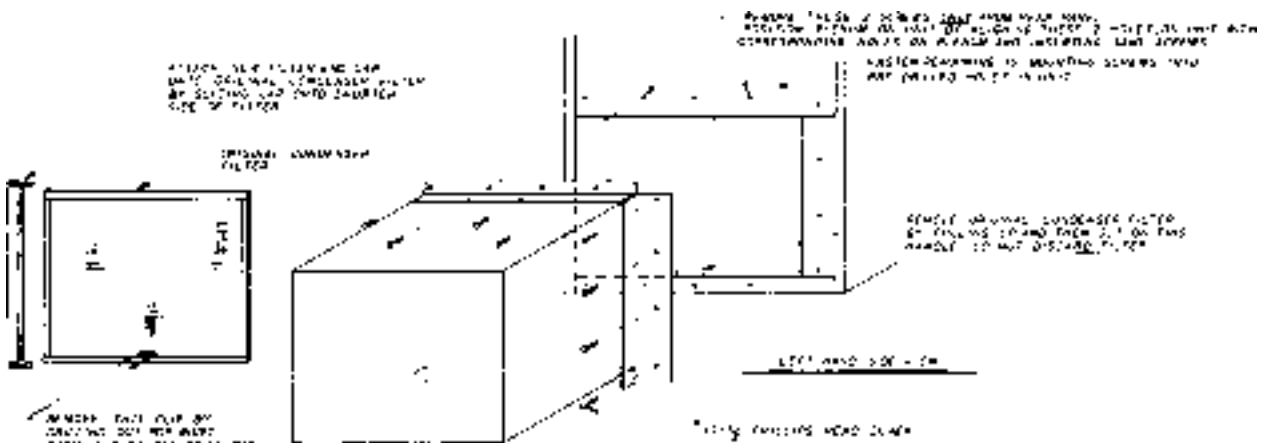
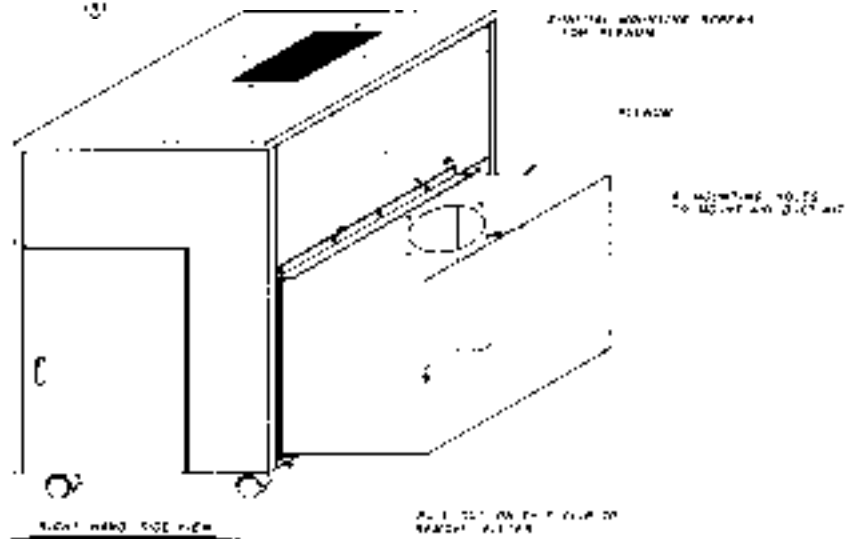
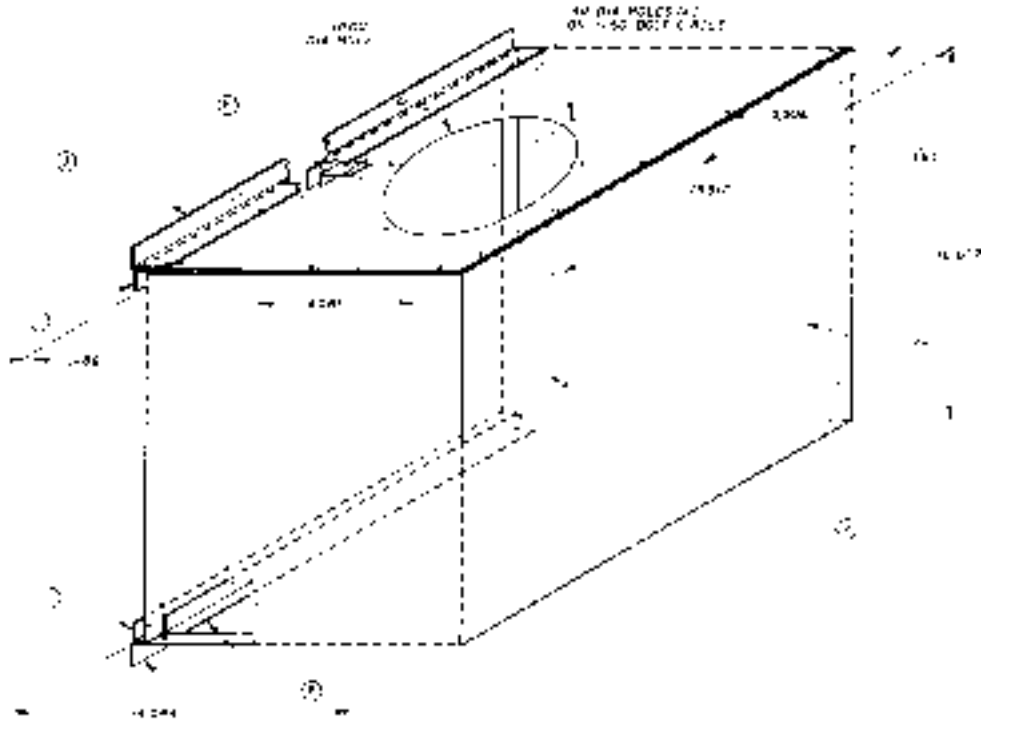

KOLDWAVE 4AK (AIRMASTER)

APPLICATIONS

ZONE COOLER

Koldwave Airmaster can be employed in an open environment as a zone cooler to cool a specific object which the evaporator grilles or the optional snozzles® direct the air toward. In this application, ducts for condenser air intake and hot air exhaust are not required. Zone cooling provides convenient, economical and energy efficient air conditioning in areas where cooling the entire environment is impractical. It directs cool air only where aimed and needed without wasting it elsewhere. Note that even though the object is cooled with a concentrated air supply, the surrounding area will slightly be heated up by the condenser's hot exhaust air. Cooling tanning-bed rooms, beauty parlors and vehicle maintenance department are just a few areas that can benefit from this application. The figure below shows a typical example of how the unit can be applied.



AREA COOLER

In a similar application where a specified area needs to be cooled a condenser hot air exhaust duct may be employed as shown in the figure below. Refer to (optional) "Flexible Duct Kit Assembly" for more details. Evaporator discharge grilles (as standard) or

optional snozzles may be used.

While evaporator discharge air cools the air directly in front of the unit, warm room air will be drawn into the rear of the unit to cool the condenser and then discharged into the false ceiling. The net effect will be a cooler area all around the unit.

When installed in an enclosed area used as a room air conditioner, the Koldwave Airmaster will require make-up air for condensing. A return air plenum and return air ducting are available to supply condensing air from outside the conditioned space.

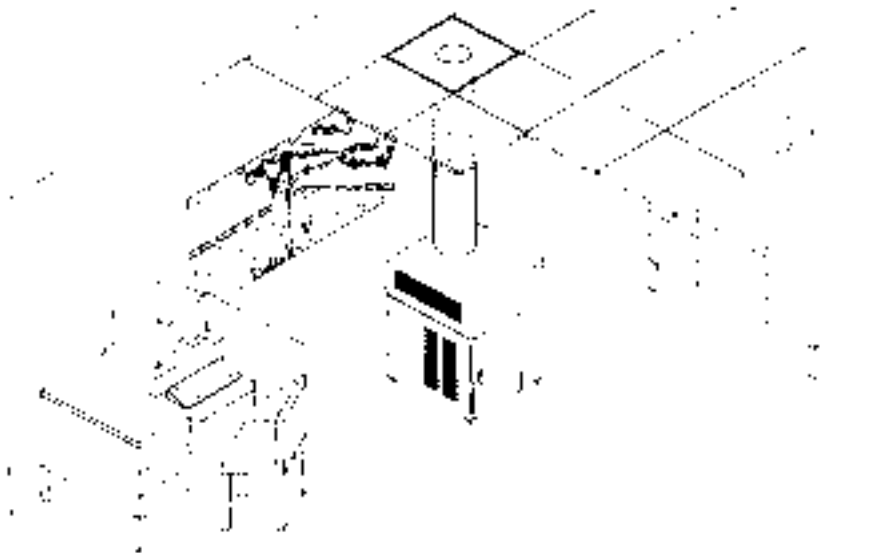

KOLDWAVE 4AK (AIRMASTER)

ROOM AIR CONDITIONER

Koldwave Airmaster may also be used as a room air conditioner to cool the entire enclosed space it is placed in. In this application, hot exhaust air venting and condenser air intake ducting are definitely needed. This can be accomplished by employing the "Flexible Duct Kit Assembly" (optional) and the "Condenser Return Air Plenum" (optional) as specified in the "Optional Features" section. See figure below for orientation of flexible ducts.

The condenser coil is cooled by the air drawn from the false ceiling. The air passes through the hot condenser coil, gets heated up, then discharges to an area outside the room being cooled (outdoors).

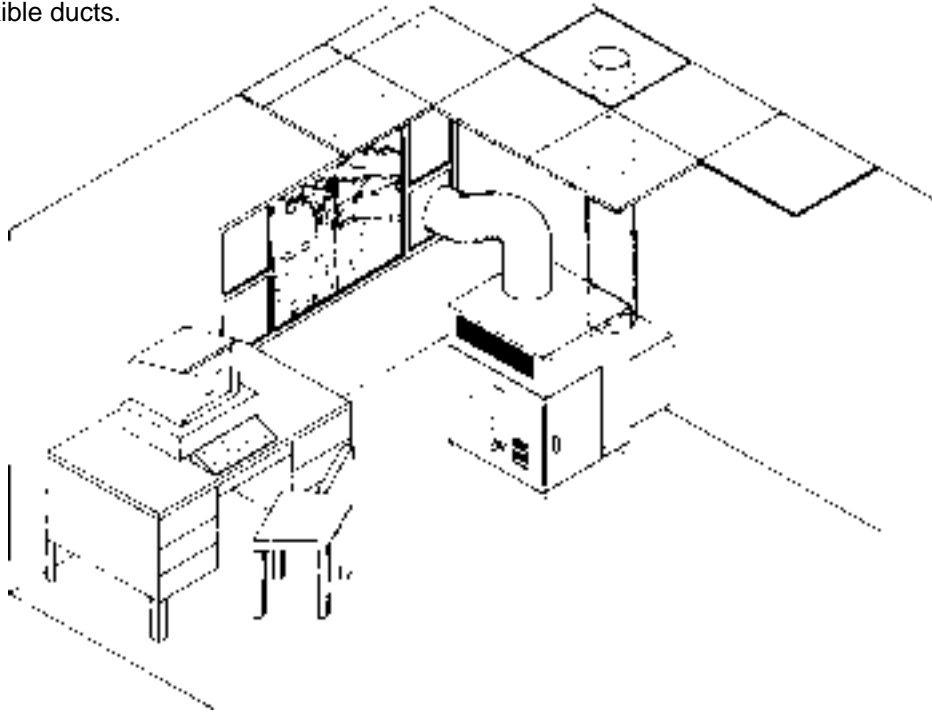

INSTALLATION INSTRUCTIONS

Before installing: Check the air conditioner/spot cooler for any shipping damage. Air conditioners are thoroughly inspected at the factory and carefully packed. If any damage is evident, file a claim with the delivering carrier immediately.

Electrical requirements: Check the data plate on the unit to make certain that the proper power is available. Refer to "Specifications" section for voltage, fuse requirements and proper NEMA receptacles. Check for proper wall outlet as described in "Standard Features" section. Operating the unit on improper voltages will void the warranty.

CAUTION: An extension cord can be used provided it is rated at least 20 amps @ 115 volts with grounding-type attachment plug and grounding type connector (load fitting).

Koldwave Airmaster portable air conditioner/spot cooler requires minimal installation. It merely plugs into a NEMA 5-20R receptacle for 4AK14 or 5-15R for 4AK10 and immediately begins to cool. The entire system is built into one compact unit which can be moved and installed easily.

Applications

ZONE COOLER

Koldwave Airmaster is designed for maximum versatility to withstand high ambient temperatures on both indoor and outdoor installations whether used for primary, emergency back-up, or supplemental cooling.

It can be employed in an open environment as a zone cooler with the evaporator grille or the optional snozzles[®] directing or focusing the powerful stream of refrigerated air on a specific object. In this application, the hot air exhaust duct is not required, especially if it is used outdoors.

Zone cooling provides convenient, economical, and energy-efficient air conditioning in areas where cooling the entire environment is impractical. The cool air is directed only where it is aimed or needed without wasting it elsewhere. Note that even though the object is cooled with a concentrated air supply, the surrounding area will be slightly heated up by the condenser's hot exhaust air.

With the addition of the flexible ducts to direct the cold air and other accessories, Koldwave Airmaster can be placed almost anywhere floor space is a premium, thus giving it multiple applications.

Some examples of the Koldwave Airmaster's convenient and efficient zone cooling are their use by athletic teams to cool dugouts and sidelines, and cooling a tent, as illustrated below.

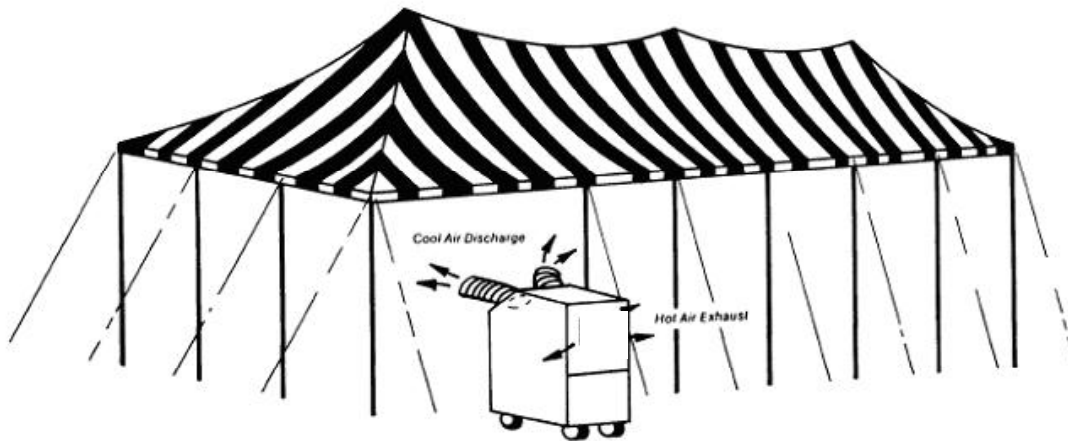

AREA COOLER

In a similar application where a specific area needs to be cooled, a condenser hot air exhaust duct may be employed as shown in the figure below. Refer to (optional) “Ceiling Panel/Duct Kit Assembly” on page 10 for more details. Evaporator discharge grille or optional nozzles[®] may be used.

While evaporator discharge air cools the air directly in front of the unit, warm room air will be drawn into the side of the unit to cool the condenser and then discharge into the false ceiling or out a window. The net effect will be a cooler area all around the unit.

Cooling vehicle maintenance areas, temporary workstations, loading docks, and packing areas are just a few examples.

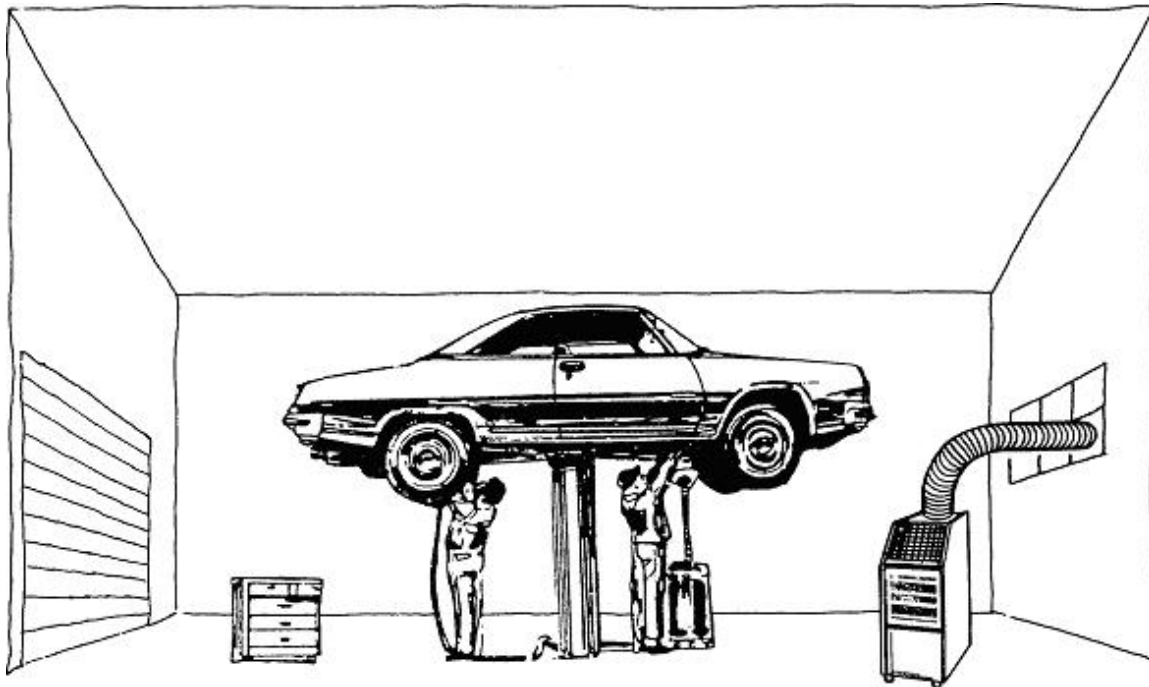

Unit Operation

Unit Power On:

Plug in the unit to the power source. The LED display will show the current controller version number for 0.5 second. Then, the LED temperature indicator will illuminate the set point for 5 second and then switch to the room temperature reading. The Power RED LED will illuminate. By depressing any mode button, the Power LED will turn off.

Fan Hi:

Depress the FAN HIGH button, the unit will be in fan mode and the evaporator fan blower will operate at High Speed. The GREEN LED will illuminate accordingly.

Fan Lo:

Depress the FAN LOW button, the unit will be in fan mode and the evaporator fan blower will operate at Low Speed. The GREEN LED will illuminate accordingly.

Cooling Hi:

Depress the COOL HIGH button, the unit will be in cooling mode pending on thermostat reading. The compressor will turn on based on the thermostat reading and the Compressor Off Time setting. The evaporator fan blower will operate at High Speed. The BLUE LED will illuminate accordingly.

Cooling Lo:

Depress the COOL HIGH button, the unit will be in cooling mode pending on thermostat reading. The compressor will turn on based on the thermostat reading and the Compressor Off Time setting. The evaporator fan blower will operate at Low Speed. The BLUE LED will illuminate accordingly.

Temperature Setting:

During any mode of operation, user is able to change the set point by depressing the arrow buttons. The temperature indicator will switch to display “set point temperature”. By depressing the ARROW UP or ARROW DOWN button will change the set point. The SETPOINT LED will illuminate. The temperature indicator will switch back to display “room temperature” after 5 second.

Unit Off:

Depress OFF button at any time to turn the SYSTEM MODE off. The unit will remain idle until further instruction. The Power RED LED will illuminate.

Other Settings:

During the cooling mode, the compressor will only be energized if the temperature is at least 2 degrees above the set point, and de-energized once the temperature falls to 2 degrees below the set point. User is able to manually change the temperature differential (default set at 2) by depressing both UP and DOWN arrow key and then adjust UP and DOWN arrow to set the differential from 1-4 degrees. After 3 seconds, it will return to the room temperature reading.

Compressor Off Time:

Our compressor routine guarantees a 5-minute minimum off time on the compressor, and it will not energize until the 5-minute off time has been satisfy.

Self Recovery Mode (*):

Our unit controller is equipped with self-recovery mode that with any sudden power interruption, the set point and operating mode are stored in memory and the unit will retain these settings and resume operation once power is restored. When the self-recovery mode is enabled the decimal point on the second character on the LED display

is always On. If self-recovery mode is not enabled that the second decimal point is always Off. However, the user is able to enable the “Self Recovery Mode” by depressing the OFF button for “5 second” and then adjust the setting from the arrow key.

A0 – Self Recovery Mode “off” (Factory Default Setting)

A1 – Self Recovery Mode “on”

Check Alarms:

The controller will monitor and check the status of four alarm signals:

1. Alarm_High_Press (E.H),
2. Alarm_Low_Press(E.L),
3. Alarm_Tank_Full (E.F),
4. Alarm_Temperature_Sensor (E.S).

When **E.F**, or **E.S** alarm is present, the **Power LED** will blink, signaling that the alarm condition is present and unit will lock out. Once the failure is clear, press the OFF button, the Power LED will stop blinking and room temperature will display.

Auto Reset High/Low Pressure switch:

If the High Pressure/Low Pressure Switch trips, "**H.P/L.P**" is displayed until the failure clears. Once failure clears the unit goes back to the previous mode it was in before the trip. If the High Pressure Switch trips 3 times within 30 minutes, the unit is locked out, forced into the Off position, and "**E.H/E.L**" is displayed on the display and **Power LED** will blink, signaling that the alarm condition is present. Once the failure is clear, the room temperature will display and the unit can be manually reactivated by pressing any mode button.

Optional Remote Control:

The optional remote control will have the identical function as the main unit excludes the followings:

1. Ability to change the “temperature differential” setting. User can only adjust such setting through the main unit panel.
2. Ability to enable or disable the “self recovery mode” setting. User can only adjust such setting through the main unit panel.

* User is only allowed to change setting when unit is OFF*



Unit Control Panel



Optional Remote Control

Before troubleshooting this system, read this manual to determine electrical power and installation requirements to allow the spot cooler to perform at its maximum efficiency. Refer to general description, wiring diagrams and photographs to get an understanding of how the unit functions.

Service other than routine maintenance should be performed only by a qualified refrigeration service person. In service/troubleshooting, there is no substitute for a good understanding of the Koldwave Airmaster modes of operation, control systems, components and safety systems.

Inspection and Repair of Refrigerant

Attentively check all connections and every part for leaks whenever the refrigerant system is repaired. Use a leak detector or the halide torch to inspect the system.

When repairing a refrigerant leak, the brazing flame will cause oxidation to occur inside the copper tubing being repaired. It is therefore desirable to use a slightly reduced flame and to flow dry nitrogen gas through the refrigerant piping while brazing to prevent this oxidation from taking place. Once the repaired is completed, thoroughly evacuate the refrigerant system with a vacuum pump before recharging the system.

Parts Replacement Procedure

Make sure the power cord is unplugged from the wall outlet and discharge all capacitors before doing any service on the unit.

To gain access to unit keypad control panel, remove phillips head screws on the left side panel.

Condenser Fan Motor

To gain access to condenser fan motor, remove right-hand and left-hand side panel, upper back and lower back panels, plus electrical box cover. Disconnect fan motor wires from capacitor, fan speed control and terminal strip. Loosen set screws in blower wheel. Unfasten clamp around motor housing and replace motor, reversing procedure.

Condenser Blower Housing

To replace the condenser blower housing, first remove the right-hand and left-hand side panels, plus upper back panel. Next, remove the condenser blower panel

assembly. Then remove six sheet metal screws securing the housing to the blower panel. Next remove the condenser fan motor as described in "Condenser Fan Motor". Replace and install a new housing by reversing the above procedure.

Evaporator Fan Motor Assembly

Pull condenser filters out. Remove right and left-hand side panels. Disconnect fan motor wires from capacitor and fan speed switches. Loosen set screw in blower wheel. Unfasten clamp around motor housing and install new motor reversing above procedure. To replace blower housing, remove nuts and screw securing housing to evaporator panel.

Tank and Micro-switch

Access the condensate holding tank located in the bottom front section by pulling down the hinged bottom front door. The holding tank's water level detection system can be reached by removing the right-hand side panel.

Compressor

To service the compressor remove right-hand side panel.

High and Low Pressure Control

Remove lower back panel and loosen pressure control capillary tube to schrader fitting in compressor discharge and suction lines. Replace high-pressure and low-pressure control, reversing above procedure.

Removal of Condenser Baffle

To gain access to condenser baffle, remove both right-hand and left-hand side panels, plus top back and condenser blower panels from the unit. The baffle is located between protective screen and the blower housing discharge opening

Preventative Maintenance

Koldwave Airmaster portable spot cooler

has been designed to give maximum performance and reliability with minimum maintenance. Maintenance of the system is concentrated in three areas covered in the following paragraphs.

Blower Motors

Caution: Always disconnect power source before working on or near a motor or its connected load.

Motor may require periodic cleaning to prevent the possibility of overheating due to an accumulation of dust and dirt on the windings or on the motor exterior.



Filter

The life of a filter depends entirely on its environment and use. It is recommended that air filters be inspected on a regular basis every four to six weeks. A clogged filter will cause the unit to operate at greatly reduced efficiency. This unit employs one 1/2" thick, washable aluminum mesh air filter located behind the louvered front (evaporator) panel and two on the left side (condenser) panel. The evaporator filter can easily be removed

and cleaned; just pull down the evaporator intake hinged door and pull the filter out. The condenser filters can be removed by lifting filters and pulling toward you and down. The filters must be washed periodically when needed. This may be done as follows:

1. Soak filter in solution of warm water and detergent for 15 minutes.
2. Rinse in clean, hot water and shake excess moisture from filter.
3. Spray one side of filter with light film of oil.
4. Reinstall with oiled surface facing out from unit.

Condensate Pump (Optional)

Caution: Always disconnect power source before working on or near the pump.

Pump Maintenance:

Do not touch or clean the sensor device with sharp objects or tools. The sensor element is fragile so handle with care. Replace pump if damaged in any way. If servicing, clean carefully with a soft brush cloth or under a slow running tap. Rinse out tray thoroughly.

Do not use solvent based cleaning agents. Only mild detergents may be used, but rinse thoroughly before refitting.

Do not use if the pump or its cable is damaged in any way. Protect cable and tubing from sharp edges.

Electrical Diagram

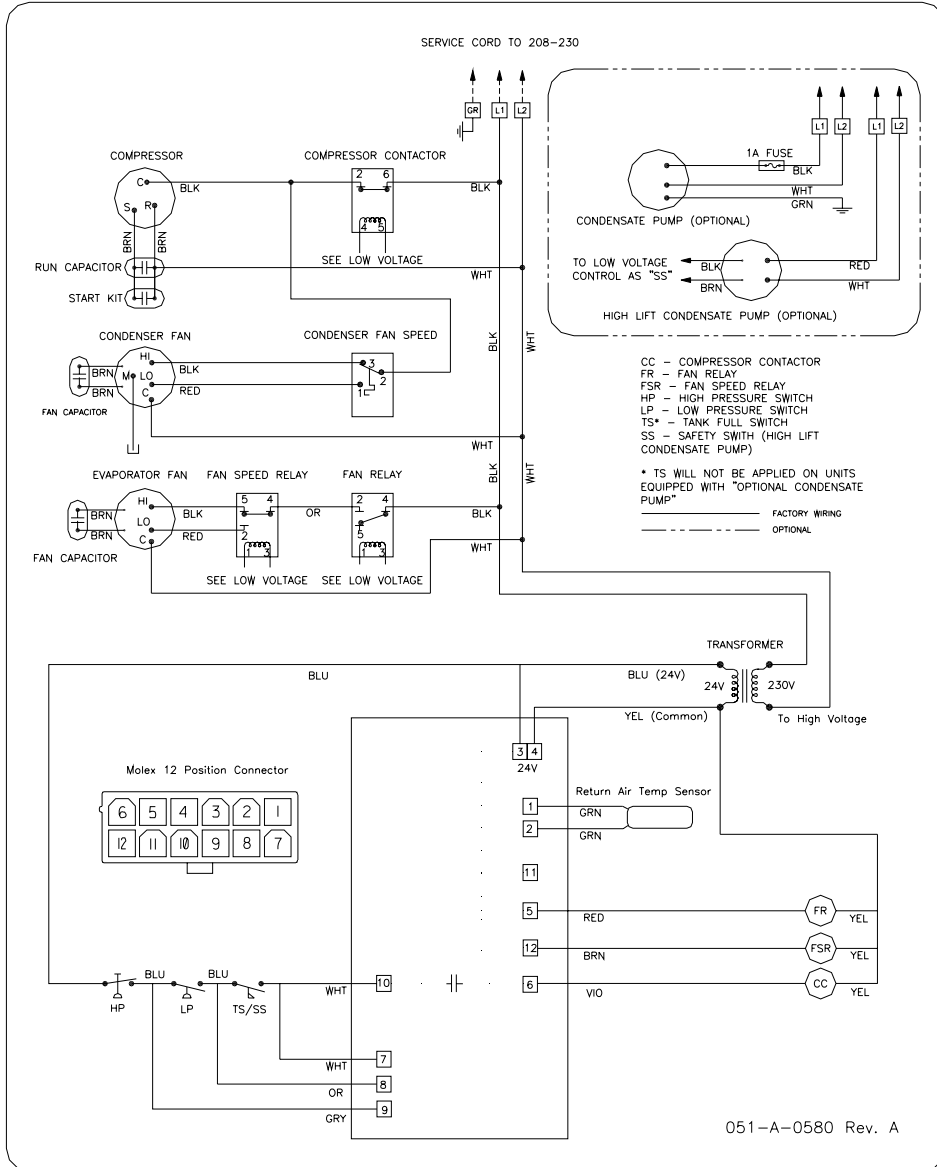

Piping Diagram

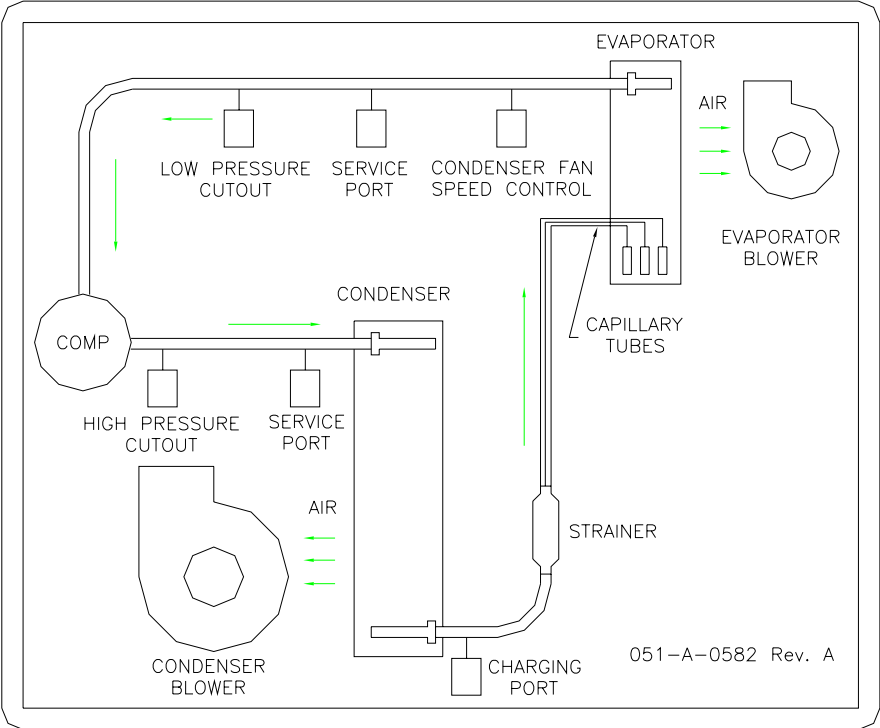

Trouble Shooting Guide

Problem	Symptom	Possible Cause	Remedy
Unit does not operate	Entire unit does not operate.	1 Power interruption.	1 Check external power supply and reset button on power cord.
		2 Defective tank full unit cutout switch	2 Check and replace.
		3 Condensate tank could be full, but indication on the keypad might be missing.	3 Check tank and replace control keypad.
	Compressor starts, but stops immediately.	1 Defective compressor overload relay.	1 Replace after checking current.
		2 Defective compressor motor.	2 Remove and replace.
		3 Defective run capacitor.	3 Check and replace.
	Compressor starts, but stops after a few minutes.	1 Check the keypad error message.	1 Fix the problem according to error message.
		2 Defective compressor motor.	2 Check and replace.
		3 Defective fan motor capacitor.	3 Replace after checking current.
4 Defective high or low pressure switch.		4 Check cut-out setting and replace if defective.	
5 Loose connection in electrical circuit.		5 Trace loose wire(s) and firm up connection.	
6 Unit overcharged/undercharged		6 Purge or add some refrigerant.	
	7 Dirty condenser coil and filter.	7 Clean filter and condenser coil.	
	8 Condensate tank right at trip point.	8 Empty tank.	
	9 Condenser fan running at high ESP.	9 Check to see if noise baffle has been removed or reduce duct length.	
Insufficient cooling.	Improper size of unit	1 Improper sizing of unit.	1 Check if the unit is undersized for the load. Add supplemental unit(s).
	Insufficient air flow through evaporator due to:	1 Dirty air filter in unit.	1 Clean filter
		2 Dirty evaporator.	2 Unusual condition required cleaning.
		3 Ice on evaporator coil.	3 Defrost; use fan only operating.
		4 Obstructed intake.	4 Remove obstruction.
		5 Evaporator fan motor miswired or wrong speed selected.	5 Check and replace
	Evaporator discharge air not cool. Compressor motor not running.	1 Refrigerant leak or non condensables.	1 Locate leak and repair.
		2 Cap tubes or strainer plugged	2 Check and replace.
		3 Defective compressor motor.	3 Check and replace.
		4 Defective compressor capacitor.	4 Check and replace.
		5 Defective relay.	5 Check and replace.
		6 Defective keypad.	6 Check and replace.
7 Defective wiring or connection.		7 Check and repair.	
8 Defective high or low pressure switch.	8 Check and replace.		
No cooled air discharge.	Evaporator blower motor not running.	1 Defective fan motor.	1 Check and replace.
		2 Defective fan capacitor.	2 Check and replace.
		3 Defective wiring or connection.	3 Check and repair.
		4 Defective fan speed contactor.	4 Check and replace.
		5 Defective keypad.	5 Check and replace.

Trouble Shooting Guide (Continue)

Problem	Possible Cause	Remedy
Evaporator blower not running up to full speed.	<ol style="list-style-type: none"> 1 Low voltage to unit. 2 Defective motor capacitor. 3 Blower wheel rubbing against housing. 	<ol style="list-style-type: none"> 1 Determine reason and correct. 2 Replace capacitor. 3 Inspect wheel alignment and correct.
Evaporator fan runs, but compressor does not start.	<ol style="list-style-type: none"> 1 Low voltage to unit. 2 Keypad control. 3 Loose or defective wires. 4 Stuck compressor. 5 Compressor shorted, open or burned. 6 Shorted or open run capacitor. 7 Unit in fan only mode. 	<ol style="list-style-type: none"> 1 Check power supply for proper voltage at unit plus or minus 10% of rated nameplate voltage. 2 Check the temperature control for loose wires. Firm any loose connections. Replace if defective. 3 Tug on wires to see if they will separate from connections. 4 Try a start capacitor across the run capacitor momentarily (three seconds). 5 Check for shorts, opens and grounds. Remove and replace compressor. 6 Remove and replace. 7 Change mode.
Abnormal noise.	<ol style="list-style-type: none"> 1 Loose compressor mounting nuts. 2 Defective, improper or worn rubber grommets on the compressor mounting bolts. 3 Copper tube vibrating. 4 Loose cabinet or internal component. 5 Loose blower wheel. 6 Blower wheel hitting shroud. 7 Blower bearing defective. 	<ol style="list-style-type: none"> 1 Tighten. 2 Replace. 3 Adjust by bending slightly to firm position. Separate tubes touching cabinet or each other. 4 Check and tighten loose screws. 5 Tighten screws on blower wheel to shaft. 6 Adjust wheel position on motor shaft. 7 Replace blower motor.
Water leaking from unit.	<ol style="list-style-type: none"> 1 Leaking evaporator or condensate pan. 2 Condensate pump related. 3 Defective drain hose (clogged or loose connection). 4 Defective micro-switch causing condensate tank to overflow. 5 Hole or crack in condensate tank. 	<ol style="list-style-type: none"> 1 Locate leak and repair pan. 2 Check to see if the elevation is over 19.5 ft. Otherwise, replace pump if defective. Pump will operate properly against 19.5 ft. of water total head pressure on pump. Check fuse and make sure pump is sitting level and is clean. 3 Repair or replace. 4 Remove and replace. 5 Remove and replace.
Unit tripping when plugged in	<ol style="list-style-type: none"> 1 Undesirable "Arc" from power receptacle 2 Commercial buildings do not have dedicated grounding system 	<ol style="list-style-type: none"> 1 Disconnect power completely from receptacle and reset the plug by pressing the "reset" button. Reconnect the plug to the receptacle. If tripping again, it means there is an "Arc" detected. Check and replace the electrical receptacle outlet. 2 Make sure the building where the units are being serviced have dedicated grounding system.

Compressor Troubleshooting

Starts and runs, but cycles on overload	1	Low voltage	1 Check overload protector
	2	Capacitor incorrect or defective	2 Replace start capacitor
	3	Condenser dirty, clogged or restricted	3 Clean condenser coil as described on page 18.
	4	Compressor grounded	
	5	Air or non-condensable gases in system	
	6	Wiring incorrect or defective	
	7	High head-pressure	7 Clean coils and filter, check system pressures
	8	Capillary tube or strainer restricted	
	9	Overload protector incorrect or defective	
	10	Refrigerant overcharged	
Tries to start when t-stat closes, but cuts out on overload; finally starts after several attempts	1	Low voltage	1 Check voltage at wall outlet. Must be within 10% of nameplate rating voltage.
	2	Capacitor incorrect or defective	
	3	Compressor motor requires start assist	3 Unit is equipped with hard start capacitor. Check capacitor as described on page 17 and replace if necessary.
	4	Air or non-condensable gases in system	
	5	Capillary tube or strainer restricted	
	6	System not equalized (wait 5min. before re-start	
	7	Thermostat differential too close	
	8	Discharge line restricted	
Will not start; hums, and cycles on overload protector	1	Low voltage	1 Check voltage at wall outlet. Must be within 10% of nameplate rating voltage.
	2	Run capacitor incorrect or defective	2 Check capacitor as described on page 17 and replace if necessary.
	3	Compressor grounded	
	4	Compressor motor or mechanism defective	4 Replace compressor
	5	Compressor motor requires start assist	5 Unit is equipped with hard start capacitor. Check capacitor as described on page 17 and replace if necessary.
	6	Wiring incorrect or defective	
	7	System not equalized (wait 5 min. before re-start)	

	8	Overload protector incorrect or defective	
	9	Relay incorrect or defective	9 Replace relay.
	10	High head-pressure	10 Clean coils and filter, check system pressures
	11	Compressor locked	11 Replace compressor
<hr/>			
Will not start; no hum	1	Compressor motor or mechanism defective	1 Replace compressor
	2	Wiring incorrect or defective	
	3	No power to unit	3 Check reset button on LCDI cord at wall outlet
	4	Fuse or circuit breaker blown	
	5	Overload protector tripped	
	6	Overload protector incorrect or defective	
	7	Thermostat contacts open	
	8	Thermostat set too high	
<hr/>			
Short Cycles	1	Low voltage	1 Check voltage at wall outlet. Must be within 10% of nameplate rating voltage.
	2	Capacitor incorrect or defective	2 Check capacitor as described on page 17 and replace if necessary
	3	Compressor motor or mechanism defective	3 Replace compressor
	4	Wiring incorrect or defective	
	5	Capillary tube or strainer restricted	
	6	System not equalized (wait 5 min. before re-start)	
	7	Fan motor too slow	7 Select HI speed on control panel
	8	Fan blade or motor defective	
	9	Fan blade or blower wheel stuck	
	10	Overload protector incorrect or defective	
	11	Thermostat differential too close	
	12	Low refrigerant charge	
	13	Refrigerant overcharged	
	14	Improper louver setting	
	15	Evaporator air flow re-circulation	
	16	Room A/C front or front seals missing	
	17	Unit oversized for application	
<hr/>			
<u>Run Capacitor</u>			
Burned out	1	Low voltage	1 Check voltage at wall outlet. Must be within 10% of nameplate rating voltage.

2	High voltage	2	Check voltage at wall outlet. Must be within 10% of nameplate rating voltage.
3	Compressor short cycles		

Condensor

Outlet (liquid line) hot	1	Condenser dirt, clogged or restricted	1	Clean condenser coil as described on page 18.
	2	Air or non-condensable gases in system		
	3	High head-pressure		
	4	Refrigerant overcharged		
	5	High ambient temperature	5	Install condenser air intake kit to draw air from another area

Head Pressure

Too high	1	Condenser dirty, clogged or restricted	1	Clean condenser coil as described on page 18
	2	Air or non-condensable gases in system		
	3	Capillary tube or strainer restricted		
	4	Fan blade or motor defective		
	5	Refrigerant overcharged		
	6	High ambient temperature	6	Install condenser air intake kit to draw air from another area
Too low	1	Compressor motor or mechanism defective		
	2	Capillary tube strainer restricted		
	3	Low refrigerant charge		
	4	Evaporator dirty, clogged or restricted	4	Clean evaporator coil as described on page 18
	5	Low ambient temperature	5	Install condenser air intake kit to draw air from another area
	6	Leak in system		
	7	Dirty air filter (air flow restricted)	7	Clean filter as described on page 18

Evaporator

Freezes	1	Capillary tube or strainer restricted		
	2	Fan blade or blower wheel stuck		
	3	Thermostat contacts stuck		
	4	Thermostat defective		
	5	Low refrigerant charge		
	6	Evaporator dirty, clogged or restricted	6	Clean evaporator coil as described on page 18
	7	Low ambient temperature	7	Install condenser air intake kit to draw air from another area
	8	Dirty air filter (air flow restricted)	8	Clean filter as described on page 18

Noisy Unit

1	Compressor motor or mechanism defective		
2	Compressor mounting nut loose		
3	Fan motor bearings loose or worn		
4	Fan blade bent, causing vibration		
5	'Ping' due to fan blade hitting water droplets		
6	Refrigerant overcharged		
7	Improper unit installation		
8	Low ambient temperature	8	Install condenser air intake kit to draw air from another area
9	High ambient temperature	9	Install condenser air intake kit to draw air from another area
10	Dirty air filter (air flow restricted)	10	Clean filter as described on page 18
11	Tube rattling		
12	Loose parts		

Room Temperature

Too high (insufficient cooling)	1	Low voltage	1	Check voltage at wall outlet. Must be within 10% of nameplate rating voltage.
	2	Condenser dirty, clogged or restricted	2	Clean condenser coil as described on page 18
	3	Compressor motor or mechanism defective		
	4	Wiring incorrect or defective		
	5	Capillary tube or strainer restricted		
	6	Fan blade or motor defective		
	7	Fan blade or blower wheel stuck		
	8	Thermostat set too high		
	9	Low refrigerant charge		
	10	Improper unit installation	10	Check for airflow restrictions and objects blocking front of unit
	11	Unit too small for its application		
	12	Evaporator dirty, clogged or restricted	12	Clean evaporator coil as described on page 18
	13	Leak in system		
	14	Dirty air filter (air flow restricted)	14	Clean filter as described on page 18
	15	Condenser water temperature too high		

Running

Cycle too long or unit operates continuously	1	Condenser dirty, clogged or restricted	1	Clean condenser coil as described on page 18
--	---	--	---	--

2	Compressor motor or mechanism defective	
3	Air or non-condensable gases in system	
4	Capillary tube or strainer restricted	
5	Thermostat contacts stuck	
6	Low refrigerant charge	
7	Improper unit installation	7 Check for airflow restrictions and objects blocking front of unit
8	Unit too small for its application	
9	High ambient temperature	9 Install condenser air intake kit to draw air from another area
10	Leak in system	
11	Dirty air filter (air flow restricted)	11 Clean air filter as described on page 18

House	1	Low voltage	
Circuit breaker or fuses blowing	2	Compressor short cycles	
	3	Wiring incorrect or defective	
	4	System not equalized (wait 5 min. before restart)	
	5	Improper fuses or dedicated circuit	
	6	Grounded component	

Limited Warranty

The Manufacturer warrants to the original owner that the Product will be free from defects in material or workmanship for a period not to exceed one (1) year from startup or eighteen months from date of shipment from the factory, whichever occurs first. If upon examination by the Manufacturer the Product is shown to have a defect in material or workmanship during the warranty period, the Manufacturer will repair or replace, at its option, that part of the Product which is shown to be defective.

The Manufacturer further warrants that the sealed refrigeration system (the product's compressor-motor condenser and evaporator) will be free from defects in materials and workmanship for five (5) years from date of start-up or sixty-six (66) months from date of shipment from the factory, whichever occurs first. If upon examination by the Manufacturer the Product is shown to have a defect in material or workmanship during the warranty period, the Manufacturer will repair or replace, at its option, that part of the Product, which is shown to be defective. Electrical parts (such as relays, overloads, capacitors, etc...) are included in the one year limited warranty but not with the five year limited warranty of the sealed refrigeration system.

This limited warranty does not apply:

1. if the Product has been subjected to misuse or neglect, has been accidentally or intentionally damaged, has not been installed, maintained or operated in accordance with the furnished written instructions, or has been altered or modified in any way.
2. to any expenses, including labor or material, incurred during removal or reinstallation of the Product.
3. to any workmanship of the installer of the Product.

This limited warranty is conditional upon:

1. shipment, to the Manufacturer, of that part of the Product thought to be defective. Goods can only be returned with prior written approval from the Manufacturer. All returns must be freight prepaid.
2. determination, in the reasonable opinion of the Manufacturer that there exists a defect in material or workmanship.

Repair or replacement of any part under this Limited Warranty shall not extend the duration of the warranty with respect to such repaired or replaced part beyond the stated warranty period.

THIS LIMITED WARRANTY IS IN LIEU OF ALL OTHER WARRANTIES, EITHER EXPRESS OR IMPLIED, AND ALL SUCH OTHER WARRANTIES, INCLUDING WITHOUT LIMITATION IMPLIED WARRANTIES OF MERCHANTABILITY OR FITNESS FOR A PARTICULAR PURPOSE, ARE HEREBY DISCLAIMED AND EXCLUDED FROM THIS LIMITED WARRANTY. IN NO EVENT SHALL THE MANUFACTURER BE LIABLE IN ANY WAY FOR ANY CONSEQUENTIAL, SPECIAL, OR INCIDENTAL DAMAGES OF ANY NATURE WHATSOEVER, OR FOR ANY AMOUNTS IN EXCESS OF THE SELLING PRICE OF THE PRODUCT OR ANY PARTS THEREOF FOUND TO BE DEFECTIVE. THIS LIMITED WARRANTY GIVES THE ORIGINAL OWNER OF THE PRODUCT SPECIFIC LEGAL RIGHTS. YOU MAY ALSO HAVE OTHER RIGHTS WHICH MAY VARY BY EACH JURISDICTION.